

# BL 53

## Datasheet

Rev. 12 • Update 01/2020

**AUTOMATIC**  
SYSTEMS

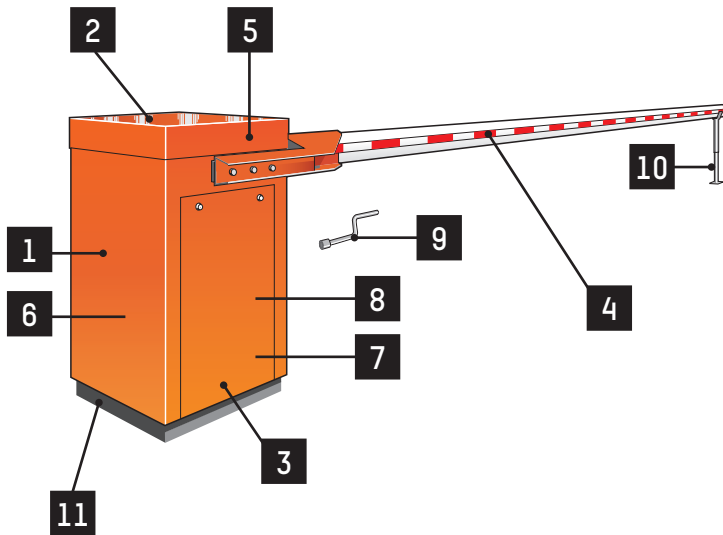

### DESCRIPTION:

1. Manufactured in shaped and welded steel sheeting 3 to 10 mm thick, with a framework of steel profiles welded into a strong section.
2. Removable upper hood, locked from the inside.
3. Two side doors with peripheral weather seals and safety lock to insure easy access to the internal mechanism.
4. Aluminium tube barrier arm with reinforced oval section of 100 x 175 mm, varnished white with red reflecting stripes and end-sealing cap. The arm is mounted in a central position on a steel pole:

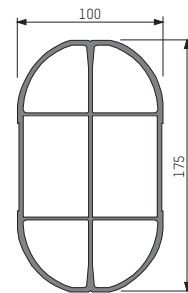

Internal stiffeners

The **BL 53** rising barrier is a heavy-duty high security barrier, with reinforced oval boom arm section, specially developed for installation where a high level of security is required.

### CONFIGURATIONS

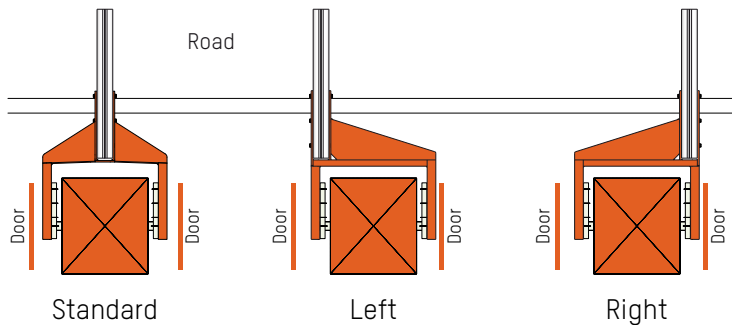

5. Arm shaft mounted on two life-lubricated ball bearings.
6. Electro-mechanical assembly comprising:
  - three-phase induction motor,
  - life-lubricated worm-screw gearbox,
  - operation by grooved pulley and V-belt making the adaptation of the operation speed possible according to the length of the boom arm,
  - movement transmission by crankshaft-rod mechanism with ball strap joints, to insure progressive shock-free accelerations and decelerations, as well as mechanical locking of the arm in end positions,
  - safety torque limiter with adjustable friction,
  - limit switches activated by adjustable cams.
7. Barrier arm balancing by means of a compression spring.
8. Programmable electronic control logic allowing various control operations and/or complementary accessories (*see related technical data sheet*). The logic protection to dust and condensation is assured by a removable hood. Electrical protection is secured by a bipolar circuit-breaker.
9. Emergency crank with safety cut-out for manual barrier operation in the event of power failure.
10. Tip support (*optional*).
11. Fixing frame made of a fixing frame with threaded rods to be fixed in a concrete base to be provided by the customer.



## STANDARD TECHNICAL CHARACTERISTICS

Power supply	Single phase 230 VAC, 50/60 Hz + Ground. <i>(Not to be connected to a floating network or to high impedance earthed industrial distribution network)</i>
Nominal power consumption	350 W.
Motor	Induction, 3-phase 250 W
Gearbox	Worm-screw, life-lubricated
Thermostatic heater	80 W.
Ambient operation temperature	From -35 to +50°C.
Boom arm balancing	By adjustable spring(s)
Useful length of boom arm (L)	From 3 to 8 meters
Position of boom arm	Central
Operation time	8 to 12 sec. according to the boom's range and the installed options
Tolerated relative humidity	95%, without condensation
Net weight <i>(without boom arm)</i>	± 340 kg
MCBF <i>(Mean Cycles Between Failures)</i>	When respecting recommended maintenance, 1.500.000 cycles
Protection index	IP44
Limit switch sensor	IP65
	EC norms compliant

## SURFACE TREATMENT

- Internal mechanical items: electrozinc coating.
- Complete housing: cationic electrodeposition coating + 1 coat of 2-component epoxy anti-rust primer and 1 top coat of 2-component polyurethane structured paint. Standard colour: Orange, RAL 2000.

## WORK TO BE SUPPLIED BY THE CUSTOMER

- Power supply.
- Electrical wiring connection to the control instruments.
- Means of fixing to the ground, according to the nature of the existing ground.

*Note: comply with the installation drawing.*

## OPTIONS

1. Left/right-hand side arm offset.
2. Height adjustable tip support.
3. Electro-magnetic tip support<sup>[a]</sup>.
4. Folding tip support<sup>[a]</sup>.
5. Bolt cover to protect arm from vandalism.
6. Security lock for crank hole closing plate.
7. Push button(s) box.
8. Key switch on housing.
9. Command by radio transmitter/receiver.
10. Inductive loops for cars or trucks detection.
11. Presence detector for inductive loops.
12. Photo electric cell *(automatic opening, closing after passage, safety)*.
13. Cell support post.
14. Cell fixed on housing.
15. Electronic board for Input/Output extension (CAN).
16. Totalling counter *(without or with reset button)*.
17. Boom lighting (LED).
18. Traffic lights (LED) fixed on a post on housing.
19. Traffic lights (LED).
20. Support post for traffic lights.
21. Electronic board for third-party traffic lights control.
22. STOP traffic sign, Ø 400 mm<sup>[a]</sup>.
23. Non standard RAL colour.
24. AISI 316L stainless steel housing.
25. Raised base.
26. 120 VAC, 60 Hz power supply *(reduces performances)*.

<sup>[a]</sup> Some options reduce the arm's range. Consult the "Limit of use" table of the price list.

## TRAFFIC MANAGEMENT OPTIONS (ON DEMAND)

27. Rotating base.
28. Stainless steel mechanical parts.
29. Treatment for aggressive saline environment.
30. IP55 enclosure on the housing.

*Note: for restrictions on the options, consult the rate table.*

# BL 53

Datasheet

Rev.12

Update 01/2020

## STANDARD DIMENSIONS (MM)

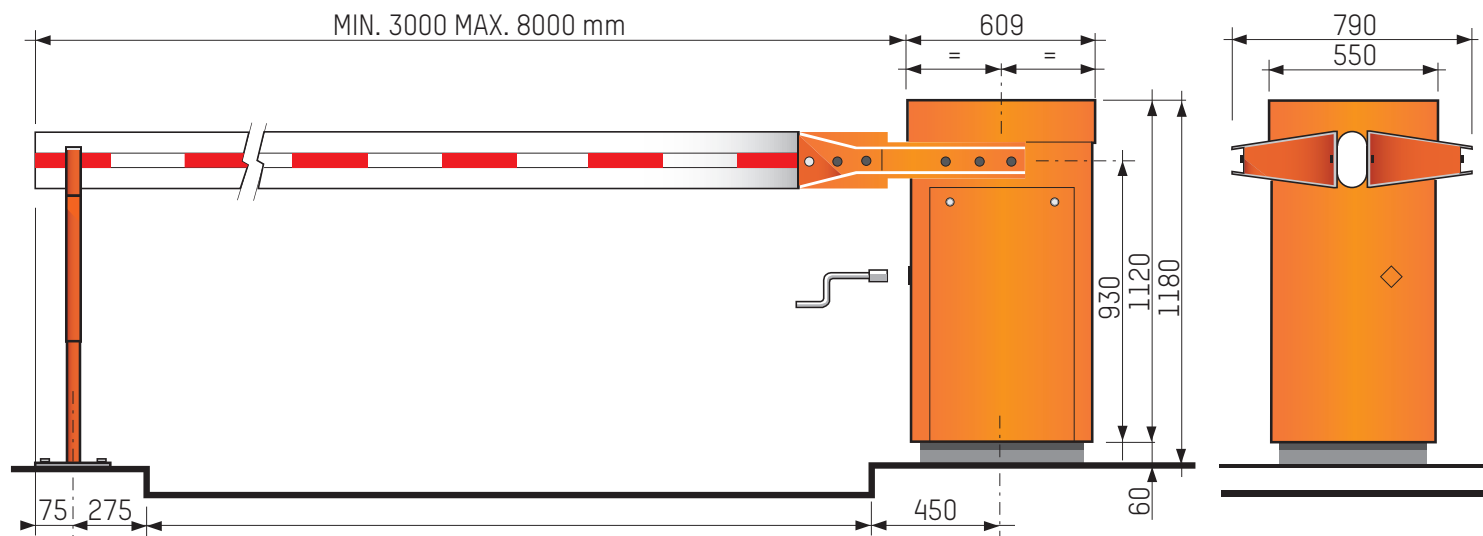

### Headquarters

Avenue Mercator, 5  
1300 Wavre - Belgium



✉ helpdesk.as@automatic-systems.com

☎ +32.(0)10.23.02.11

🌐 www.automatic-systems.com

