

BL 52

Datasheet

Rev. 11 • Update 01/2020

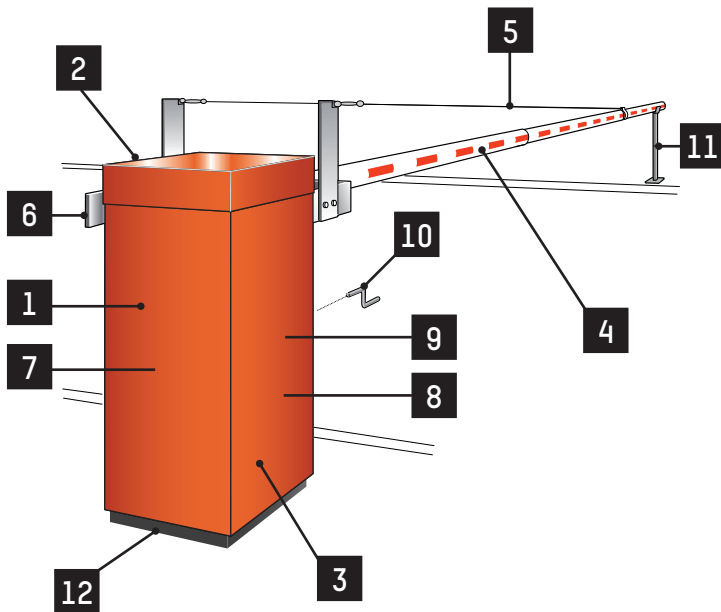

The BL 52 rising barrier is an extra-long barrier designed to control vehicle access through large entrances. Its robust and oversized mechanics makes it possible to move a boom arm up to 14 m long.

CONFIGURATIONS

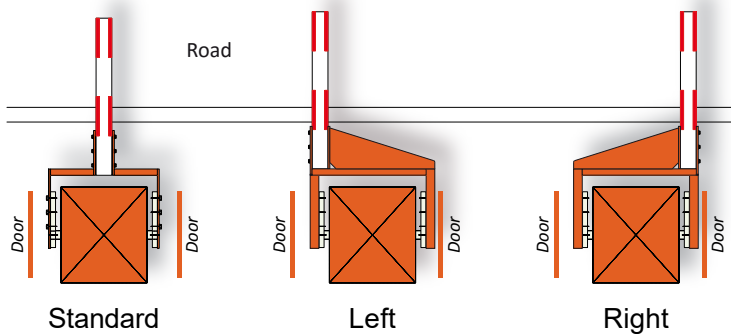

DESCRIPTION

1. Manufactured in shaped and welded steel sheeting 3 to 10 mm thick, with a framework of steel profiles welded into a strong section.
2. Removable upper hood, locked from the inside.
3. Two side doors with peripheral weather seals and safety lock to insure easy access to the internal mechanism.
4. Aluminium tube barrier arm, varnished white with red reflecting stripes. The barrier arm is composed of 3 sleeves of decreasing diameter (100/90/84 mm) with an end-sealing cap. The barrier arm is mounted in central position on a steel pole.
5. Bracing wires and slack adjusters in stainless steel. The number of braces is increased from 2 to 8 according to the boom arm length and boom arm options chosen.
6. Arm shaft mounted on two life-lubricated ball bearings.
7. Electro-mechanical assembly comprising:
 - three-phase induction motor,
 - life-lubricated worm-screw gearbox,
 - operation by grooved pulley and V-belt making the adaptation of the operation speed possible according to the length of the boom arm,
 - movement transmission by crankshaft-rod mechanism with ball strap joints, to insure progressive shock-free accelerations and decelerations, as well as mechanical locking of the arm in end positions,
 - safety torque limiter with adjustable friction,
 - limit switches activated by adjustable cams.
8. Barrier arm balancing by means of a compression spring.
9. Programmable electronic control logic allowing various control operations and/or complementary accessories (*see related technical data sheet*). The logic protection to dust and condensation is assured by a removable hood. Electrical protection is secured by a bipolar circuit-breaker.
10. Emergency crank with safety cut-out for manual barrier-operation in the event of power failure.
11. Tip support.
12. Fixing frame made of a fixing frame with threaded rods to be fixed in a concrete base to be provided by the customer.



STANDARD TECHNICAL CHARACTERISTICS

| | |
|---|---|
| Power supply | Single phase 230 VAC, 50/60 Hz + Ground. <i>(Not to be connected to a floating network or to high impedance earthed industrial distribution network)</i> |
| Nominal power consumption | 350 W. |
| Motor | Induction, 3-phase 250 W |
| Gearbox | Worm-screw, life-lubricated. |
| Thermostatic heater | 80 W. |
| Ambient operation temperature | From -35 to +50°C. |
| Boom arm balancing | By adjustable spring(s) |
| Useful length of boom arm (L) | From 6 to 14 meters. |
| Position of boom arm | Central |
| Operation time | 8 to 12 sec. according to the boom's range and the installed options. |
| Tolerated relative humidity | 95%, without condensation. |
| Net weight <i>(without boom arm)</i> | ± 340 kg. |
| MCBF <i>(Mean Cycles Between Failures)</i> | When respecting recommended maintenance, 1.500.000 cycles. |
| Protection index | IP44 |
| Limit switch sensor | IP65 |
|  | EC norms compliant |

SURFACE TREATMENT

- Internal mechanical items: electrozinc coating.
- Complete housing: cationic electrodeposition coating + 1 coat of 2-component epoxy anti-rust primer and 1 top coat of 2-component polyurethane structured paint. Standard colour: Orange, RAL 2000.

WORK TO BE SUPPLIED BY THE CUSTOMER

- Power supply.
- Electrical wiring connection to the control instruments.
- Means of fixing to the ground, according to the nature of the existing ground.

Note: comply with the installation drawing.

OPTIONS

1. Aluminium rigid folding skirt^(a) *(requires option 2)*.
2. Left/right-hand side arm offset.
3. Electro-magnetic tip support^(a).
4. Folding tip support^(a).
5. Security lock for crank hole closing plate.
6. Push button(s) box.
7. Key switch on housing.
8. Command by radio transmitter/receiver.
9. Inductive loops for cars or trucks detection.
10. Presence detector for inductive loops.
11. Photo electric cell *(automatic opening, closing after passage, safety)*.
12. Cell support post.
13. Cell fixed on housing.
14. Electronic board for Input/Output extension *(CAN)*.
15. Totalling counter *(without or with reset button)*.
16. Boom lighting *(LED)*.
17. Traffic lights *(LED)* fixed on a post on housing.
18. Traffic lights *(LED)*.
19. Support post for traffic lights.
20. Electronic board for third-party traffic lights control.
21. STOP traffic sign, Ø 400 mm^(a).
22. Non standard RAL colour.
23. AISI 316L stainless steel housing.
24. Raised base.
25. 120 VAC, 60 Hz power supply *(reduces performances)*.

^(a) *Some options reduce the arm's range. Consult the «Limit of use» table of the price list.*

TRAFFIC MANAGEMENT OPTIONS (ON DEMAND):

26. Rotating base.
27. Stainless steel mechanical parts.
28. Treatment for aggressive saline environment.
29. IP55 enclosure on the housing.

Note: for restrictions on the options, consult the rate table.

STANDARD DIMENSIONS (MM)

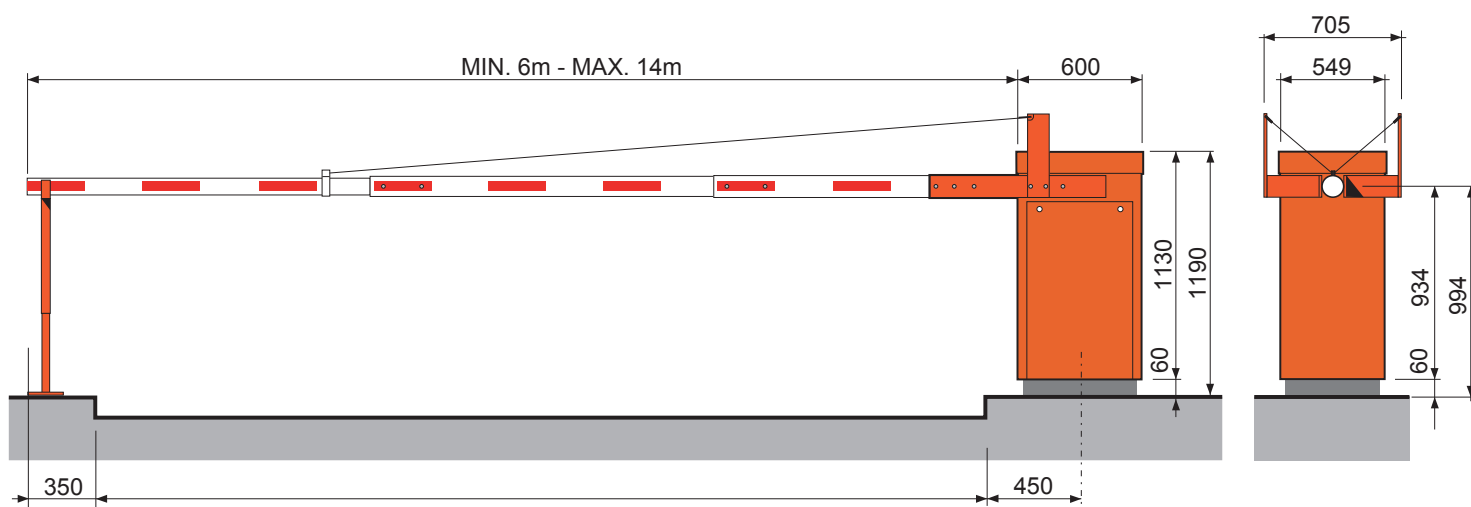

Headquarters

Avenue Mercator, 5
1300 Wavre - Belgium



✉ helpdesk.as@automatic-systems.com

☎ +32.(0)10.23.02.11

🌐 www.automatic-systems.com

