

SL 945 Twin

Datasheet

Rev. 15 • Update 08/2020

AUTOMATIC
SYSTEMS

SlimLane

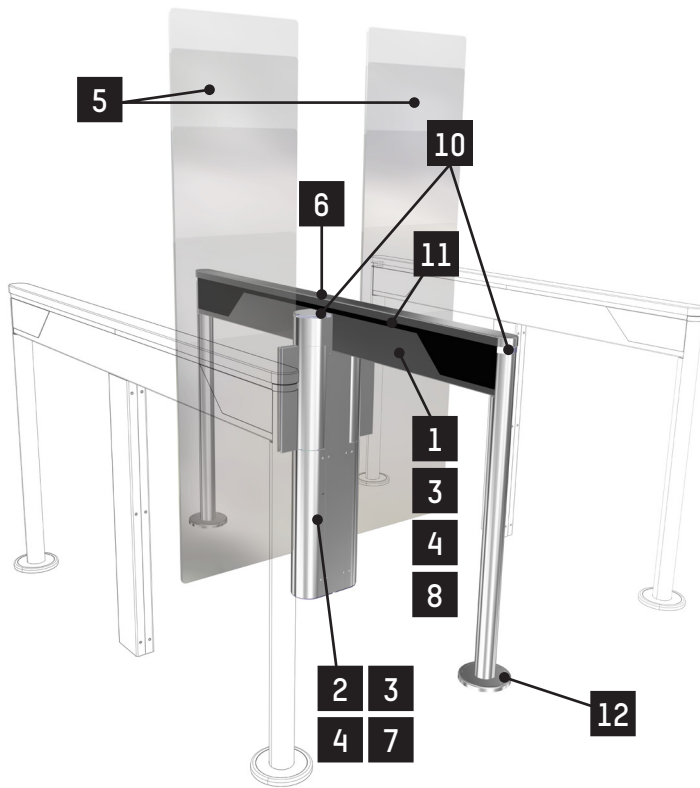

DESCRIPTION

1. Handrail frame: steel beam with RoHS anti-corrosion zinc plating treatment and stainless steel posts. The handrail includes photoelectric cells for user detection and the logic control board.
2. Self-supporting kinematic steel frame with RoHS anti-corrosion zinc plating treatment. The frame contains the electromechanical drive assembly for the swinging obstacle and the electronic control boards.
3. Brushed #4 AISI 304L stainless steel housing.
4. Brushed #4 AISI 304L stainless steel panels fastened to the frame for access to the internal components.
5. Clear, 10 mm thick tempered monolithic glass obstacles, swinging in the direction of user passage.
6. Brushed #4 AISI 304L stainless steel top cover.
7. Electromechanical drive units each consisting of:
 - A DC permanent magnet motor with epicyclic gearbox.
 - A controller providing progressive accelerations and decelerations of the obstacle, for smooth movement and enhanced user safety.
 - A geared electromagnetic brake for locking of obstacles in the event of forced entry attempts.
 - A sensor controlling the obstacle position.
 - **SECURI-SAFE** standard operating mode: electromechanical lock of the obstacles in case of forced entry attempt in any passage directions.
8. Logic control board, equipped with ARM technology and the Linux operating system, ensuring advanced traffic management. An embedded Web server, accessible by a simple web browser, offering an interface for the configuration of functional gate parameters as well as a complete diagnostic and maintenance tool.
9. Transfer of information from XML-RPC protocol through an Ethernet or USB interface, and dry contacts: passage authorisation, passage information, reader locking, fraud, equipment failure, ...
10. Orientation and function pictograms indicating gate and passage status to the user.
11. Proprietary DIRAS detection system, consisting of a high-density matrix of infrared transmitter/receiver photocells beams. It follows users progression through the gate as well as ensuring their safety during opening/closing of the obstacles.
12. Finishing plate for post.

The **SlimLane 945 Twin** single swing door security entrance lane offers a high bidirectional throughput and uncompromising security.

With its transparent, elegant design and minimal footprint, the **SlimLane 945 Twin** is designed to integrate perfectly into any architectural style.

The **SlimLane 945 Twin** offers a dual compact passageway, suitable for confined installation spaces.

Equipped with high processing capacity and an exclusive detection system, the **SlimLane 945 Twin** guarantees accurate user tracking and prevents any unauthorised use.

The **SlimLane 945 Twin** is a modular product that can be installed as a single or a multi-lane array and can also be combined with the SlimLane 944 single compact lane, the SlimLane 940 standard lane and SlimLane 950 wide lane models. It can also be completed with a service lane.

Note: Guardrails, shown in the picture above, are not part of SlimLane 945 Twin product.



SL 950 + SL 944 + SL 945 Twin



STANDARD TECHNICAL CHARACTERISTICS (PER LANE)

Electrical supply	Single phase 110-240 VAC (+/-10%) - 5A - 50/60 Hz + Ground
Power consumption	Standby: 50 W Cycle: 170 W Maximum: 300 W
Motor	24V DC – nominal output power 93 W
Passageway (L)	2 x 550 mm 2 x 505 mm < L < 580 mm (<i>min/max</i>)
Min opening or closing times	0,9 s (<i>Depending on the access control system reactivity and the speed of users</i>)
Ambient operating Temperature	0 à +50°C
Ambient relative humidity in operation	< 95%, without condensation
MCBF	5,000,000 mean cycles between failures, with recommended maintenance*
Sound level	50 dB
Weight	95 kg (<i>Kinematic unit</i>) 40 kg (<i>Handrail</i>)
IP	40
	Conforms to European standards

* Maintenance operations are detailed in the technical manuals.

PRECAUTIONS FOR USE

- For security reasons, children (user smaller than 1 m tall for mobile obstacles of 900 mm height and smaller than 1.3 m for mobile obstacles from 1200 mm to 1800 mm height) must be supervised by an adult at all times when in the vicinity of the unit and during passage through the lane.
- A child must absolutely precede the accompanying adult when lane passage is required.
- If habitual use by children is anticipated, Automatic Systems recommends the addition of all options required to optimize the level of protection.

WORK TO BE PROVIDED BY THE CUSTOMER

- Bolting the unit to the floor.
- Power supply.
- Cabling between gates in the same array.
- Cabling to any external peripherals.
- Integration of any accessories

Note: Comply with the installation drawing.

OPTIONS

1. "EGRESS" operating mode: obstacles open in the direction of egress by a simple push.
2. Battery backup for automatic opening in case of power failure and obstacle locking mechanism in egress direction.
3. Mobile glass obstacles – height of 1200, 1500, 1700 or 1800 mm.
4. End post without bottom flange.
5. Fixed external obstacle.
6. Fixings for fixed external obstacle.
7. Glass side wall with enhanced electronic protection and "trolley" protection cell kit (A and B directions).
8. Glass side wall.
9. Lighting kit for fixed side wall.
10. Personalized logo on glass – sandblast effect sticker.
11. Black top cover.
12. Paint in: RAL9005, RAL5008, RAL6014, RAL7003, RAL7016, RAL9010.
13. Extension housing (EP), including orientation pictogram (A direction or/and B direction).
14. Extended extension housing (EP), including orientation pictogram (A direction or/and B direction).
15. Angled housing on passage for extension housing.
16. Reader integration kit for extension housing or angled housing.
17. Hinged access door for extension housing.
18. Badge or token bin and hinged access door for extension housing.
19. Integrated token acceptor with receptacle and hinged door.
20. Ø 28 or Ø 30 tokens.
21. Independent support post with standard reader integration kit.
22. External support kit for reader integration on housing.
23. Fixing frame for streamlined passageway.
24. Low or high fixed handrail.
25. Raised top.
26. Raised top ready for one barcode reader IBC QSCANT (one direction) or 2 readers (2 directions).
27. Escape route button per EN 13637 norm, on the front of the right endpost (B direction).
28. Support post with escape route button per EN 13637 norm.
29. Cable draw wire for onsite installation.
30. Additional AS1168 I/O card.
31. "Smart & Slim" monitoring panel.
32. "Smart Touch" configurable interactive control panel.

Note: For restrictions on options, refer to the price list.

STANDARD DIMENSIONS (mm)

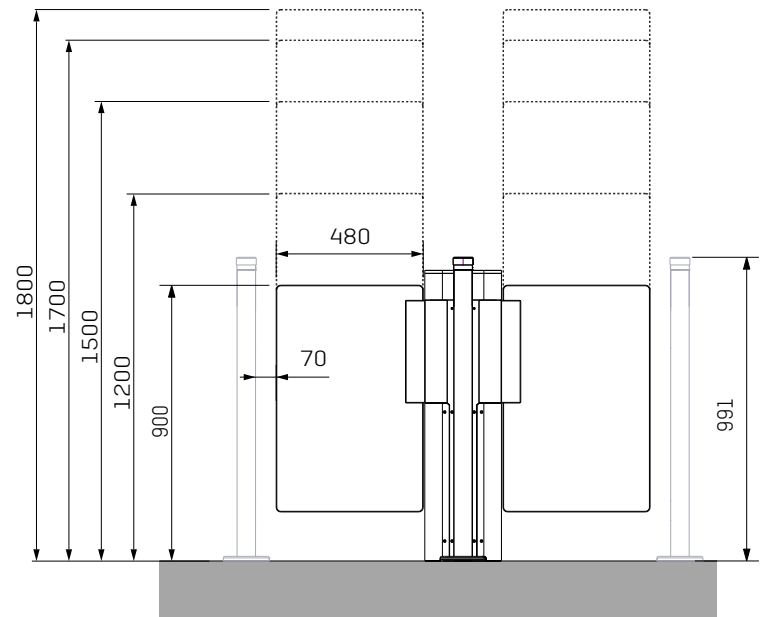
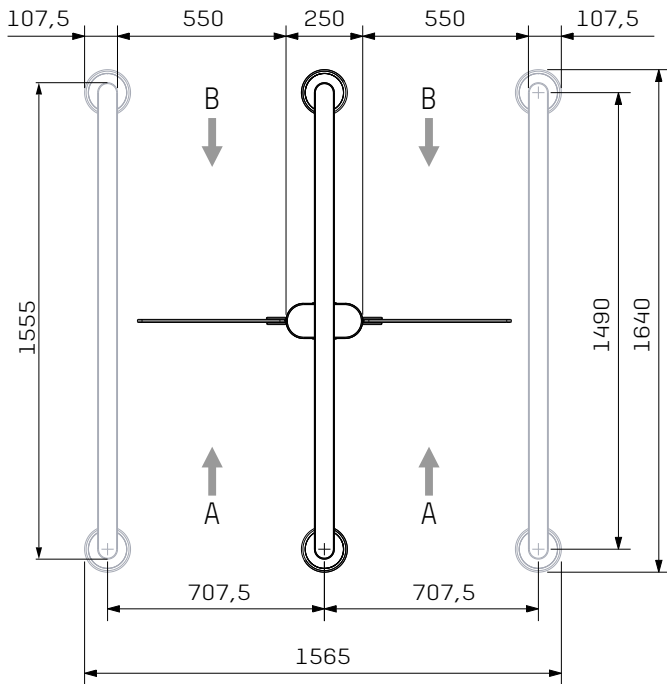

Headquarters

Avenue Mercator, 5
1300 Wavre - Belgium



helpdesk.as@automatic-systems.com



+32.(0)10.23.02.11



www.automatic-systems.com

